



Cavity Resonance

Today many microwave circuit designers note that their circuits do not perform quite as well as predicted when it is enclosed inside a circuit board housing or board level shield. A cavity resonance occurs inside a conductive enclosure when energy is generated at frequencies which correspond to the resonant frequencies of the enclosure. At the cavity resonance frequencies the resonance can provide a secondary coupling path between the energy source and a victim. Additionally, the field structure of the resonance can adversely impact the circuit impedances in the cavity with unknown impact on circuit operation. Cavity resonant frequencies can be calculated based on the proportion of wavelength to cavity size. With operating frequencies increasing (and wavelengths decreasing) this is becoming an increasingly prevalent issue in circuit design.

What is a cavity resonance?

Solutions to the field equations inside an enclosed space reveal that standing wave modes may exist inside a cavity. These modes can exist in an empty rectangular cavity if the largest cavity dimension is greater than or equal to one half a free space wavelength. Below this cutoff frequency the cavity resonance cannot exist.

For a rectangular cavity with dimensions a , b , c with $a < b < c$ which is completely filled with a homogeneous material the equation for the resonant frequencies is

$$(f)_{mnp} = \frac{1}{2\sqrt{\epsilon\mu}} \sqrt{\left(\frac{m}{a}\right)^2 + \left(\frac{n}{b}\right)^2 + \left(\frac{p}{c}\right)^2}$$

where ϵ is the material permittivity and μ is the material permeability^j

In this configuration the TE_{011} mode is the dominant mode or the lowest frequency at which a cavity resonance can be supported. The frequency of the dominant mode is inversely proportional to the square root of the magnitude of the material parameters. If your frequency of operation is below the cutoff frequency of the cavity then you will not have a problem with cavity resonance as it will not be able to exist.

Cavity resonance becomes an issue when a circuit is designed and built and works well but then must be protected and/or shielded with a circuit board cover. For shielding purposes the covers are made of or lined with metal. This creates a cavity above the circuit board where resonances can exist. With operating frequencies going higher into the microwave and millimeter wave band cavity resonance effects have become a major problem.

In a cavity resonance standing waves form where energy does not propagate but oscillates. Note that a standing wave has the characteristic that the electric (E) and magnetic (H) fields are 90° degrees out of phase with each other which means at points where the E field is at a minimum, the H field is at a maximum and vice versa. The impedance (which equals E/H) will therefore fluctuate wildly across the cavity causing unknown (usually bad) effects on circuitry including the introduction of instability to active devices. The H field also is at its maximum at the wall of the cavity which may cause the shielding effectiveness to deteriorate at the resonant frequencies. Often what is perceived as a shielding issue requiring attention to shielding materials is actually a cavity resonance issue. Additionally, the resonance provides a secondary undesired coupling path across the cavity

Relocating a circuit element to a different position in the cavity can often fix the problem. Intelligent positioning of posts or other objects to disrupt the standing wave can also be helpful but both these methods can involve an investment in engineering design time and possible manufacturing delays.

To gauge the impact of various absorber types and configurations a model was developed within Ansys HFSS. Two ports are located within a conductive rectangular cavity. The excitations are in the form of a current loop oriented vertically. Measurements have verified that this is the closest representation of the radiation pattern of an IC. In general within the model, the loop dimensions are much smaller than a wavelength, hence they are inefficient radiators. Direct coupling between the ports without the cavity is negligible. However, once placed inside the cavity, considerable coupling will occur between the ports at the cavity resonant frequencies.

In this study, 5 different rectangular shield sizes were analyzed as listed below. The fundamental physics of resonance do not differ between the cases however when we analyze the effect of absorbers inside the cavity, the frequency dependence of the absorber electromagnetic parameters will come into play.

Dimensions	Frequency range	First cavity resonance frequency
8" x 14.75" x 0.75"	600 MHz-3 GHz	839 MHz
4" x 6" x 0.5"	1.5 GHz-4.5 GHz	1.77 GHz
1" x 1.8" x 0.3"	6 GHz-18 GHz	6.75 GHz
0.6" x 1.0" x 0.25"	8 GHz-40 GHz	11.47 GHz
0.3" X 0.5" x 0.1"	15 GHz-90 GHz	22.95 GHz

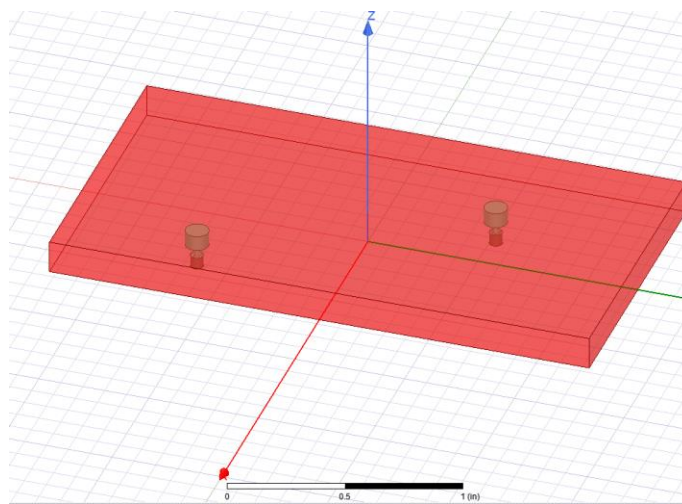

Below is the modeled calculation of S21 or coupling between the two ports in the cavity when the cavity is empty. Note the very low coupling at frequencies below the first cavity resonance frequency increasing sharply to very high coupling at the first resonant frequency (around 839 MHz). There is also significant coupling at the next two resonant frequencies (around 1.1 GHz and 1.4 GHz). At higher frequencies representing higher order resonant modes there are still coupling peaks. Coupling is not as high as at the lower order modes however this is likely due to port placement where the modes are not efficiently excited.

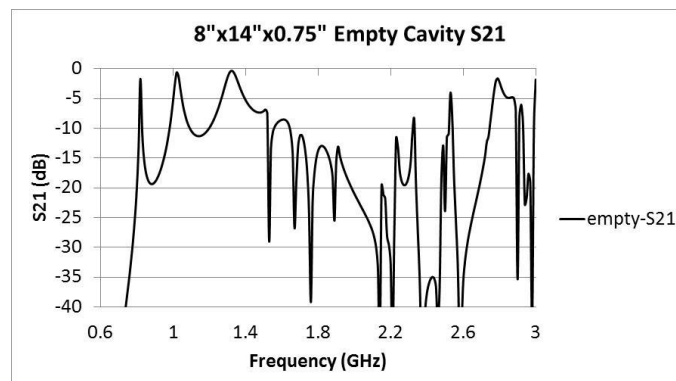

Next, a thin sheet of absorber was placed on the underside of the top of the cavity as seen below.

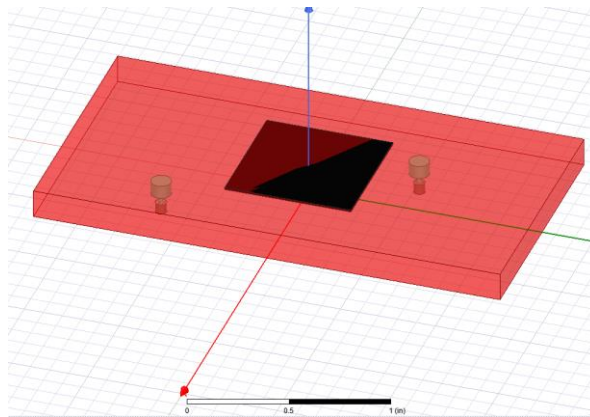

The absorber type is ECCOSORB MCS. There are two effects of absorber in the cavity. The first is that the presence of any material in the cavity will lower the cavity resonance frequencies. Absorber in general has high permittivity (ϵ) and high permeability (μ). From inspection of the cavity resonance equation shown previously, permittivity or permeability greater than 1 will lower the resonant frequencies.

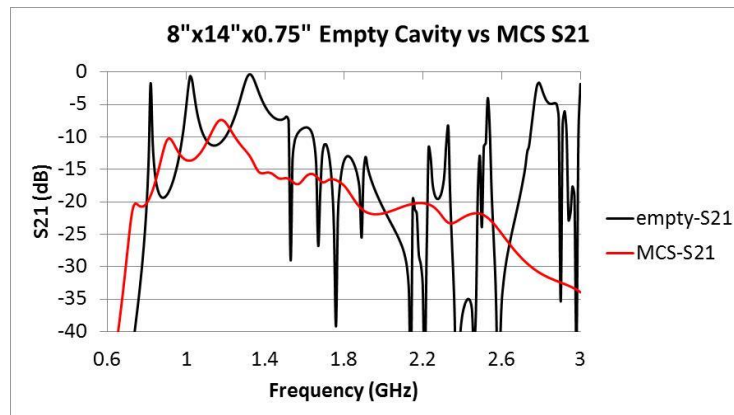

In addition to the frequency shift caused by the introduction of the absorber, the absorber serves to reduce the coupling between ports which is analogous to reducing inter-component interference inside the cavity. Note that due to the frequency shift, the absorber will actually increase coupling at certain frequencies, in general the coupling level is sufficiently low. Below are similar graphs for the other size cavities. Note that the smaller the cavity, the higher the resonant frequencies. Also note that each cavity size uses a different absorber type. As mentioned previously, cavity resonance physics is identical for any size cavity however the best absorber for each application will differ based on the absorber properties at the frequencies of interest. Absorber parameters are frequency dependent, hence different absorbers are recommended for different frequency ranges.

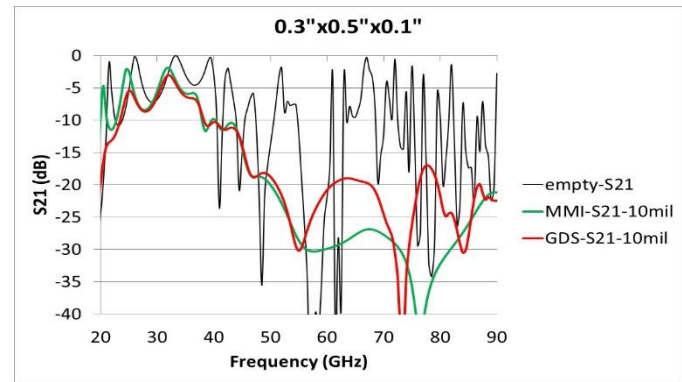
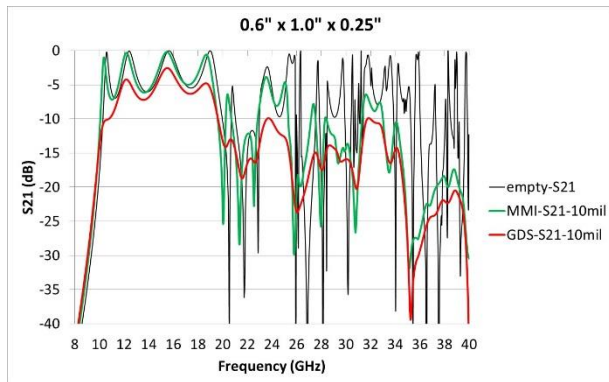
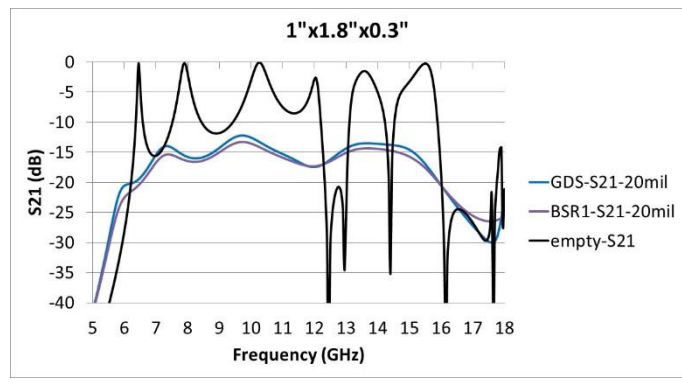
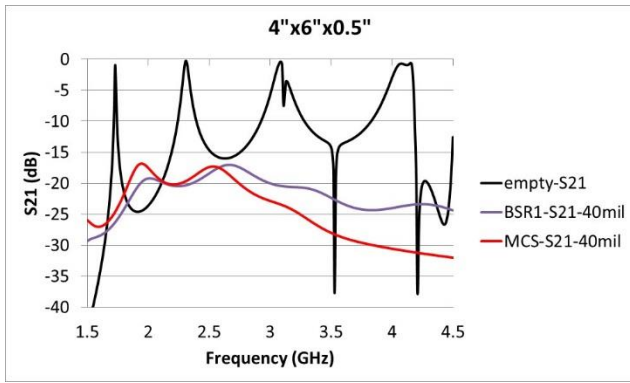

Absorber Properties

Now what are the properties of an absorber that would make it effective in damping a cavity resonance? From the field equations above we note that the tangential electric (E) field on a conductive boundary is equal to zero while the tangential magnetic (H) field is at a maximum. Therefore an absorber that absorbs primarily the magnetic field would be desired since the absorber is generally placed on the conductive wall of the cavity. High values of the absorber permittivity and permeability are also desirable. Solutions to the field equations show that in a cavity with a material inside, most of the energy will reside inside the material with high permittivity and permeability. The higher these values, the higher the energy concentration inside them. This serves to remove the resonating energy from the vicinity of the circuit so it can function properly.

Note that at low frequencies in the largest cavity (8" x 14" x 0.75"), ECCOSORB MCS has the best performance. MCS contains a blend of filler that are designed to absorb at lower frequencies. MCS is still effective for the second largest cavity (4"x6"x0.5") but ECCOSORB BSR-1 is also effective. BSR-1 and GDS are equally effective in the next largest cavity (1"x1.8"x0.3") where resonances are in the 6-18 GHz range. Either would be a viable solution. For the next largest cavity (0.6"x1.0"x0.25") the resonances are moving into the millimeter wave range. GDS is still a good solution in this frequency range but MMI is very close. For the smallest cavity (0.3"x0.5"x0.1") MMI is the clear winner in the upper mmWave band. The interesting point here is that MMI is a pure dielectric absorber. It has no effect on the magnetic field. Above it was stated that the most effective cavity resonance absorbers act on the magnetic field. The reason MMI is more effective in the upper mmWave band is that the active filler used in GDS material begins to lose effectiveness above 40 GHz or so. The good news is that since the wavelengths are so small at these frequencies, even a purely dielectric absorber can be effective at eliminating cavity resonances.

Frequency	Recommended Material
1-6 GHz	MCS
6-18 GHz	BSR-1
18-40 GHz	GDS
40-90 GHz	MMI

Absorbers are characterized by their permittivity (response to E field) and permeability (response to H field). Each component has two parts, real and imaginary. The real portion is primarily responsible for wavelength compression and interface reflection while the imaginary part is primarily responsible for loss (absorption). Note that MCS has high

permittivity and permeability as well as high imaginary permeability (Imag mu), making it an ideal cavity resonance absorber at low frequencies.

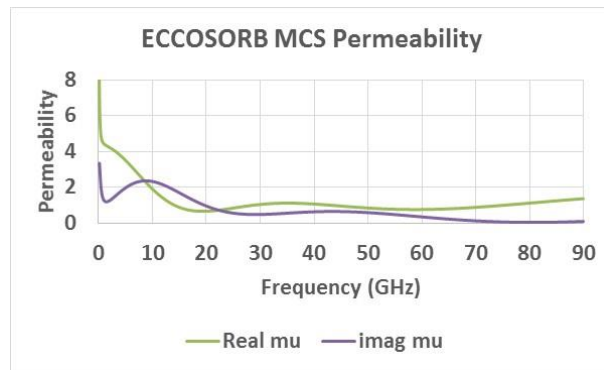
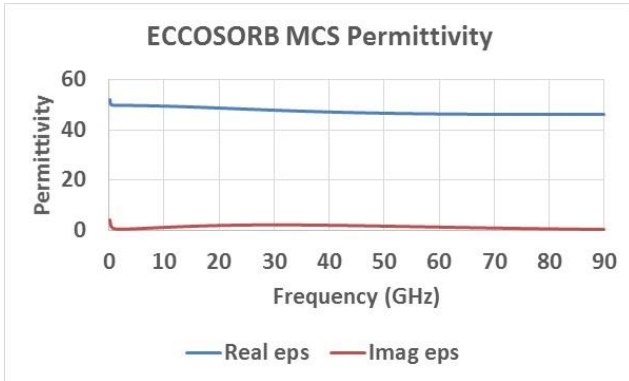

Cavity Resonance and Shielding

Intra-component coupling is not the only negative manifestation of cavity resonance. Often the cavity enclosure is needed to provide some shielding to electromagnetically protect components inside or protect outside components from EMI or to satisfy regulatory requirements. Below is a graph indicating the shielding effectiveness of an empty cavity, when the cavity is ¼ filled with a dielectric material of dielectric constant (dk)=5 and when the cavity is ¼ filled with a magnetically loaded absorber. The vertical lines indicate the cavity resonant frequencies. Note the significant drop in shielding effectiveness at the cavity resonant frequencies. This is due to the resonance maximizing the magnetic field strength on the inside of the shield which then excites any apertures in the shield which radiate. The addition of the dk=5 material lowers the cavity resonance frequencies of the cavity, hence the drop in SE is seen at a lower frequency. The addition of the absorber material reduces the cavity resonance frequency still more but it can be seen how it increases SE at higher frequencies. This is due to the resonance damping of the absorber.

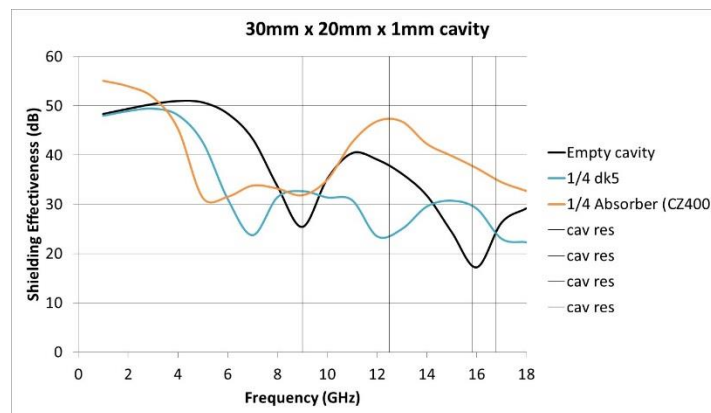

Absorber placement in cavity

It is rarely if ever necessary to treat all the cavity walls with absorber. It is usually not even necessary to treat the entirety of one wall. Unfortunately it can be very difficult and time consuming to determine the optimum absorber placement. Absorber manufacturers have generous sample policies for just this reason. It is difficult to determine a priori where the optimum absorber placement would be. Sometimes the absorber acts to damp the resonance. Other times it acts to shift the standing wave resonance (SWR) peaks to a less detrimental location. There are general guidelines for absorber placement. Placing the absorber at the standing wave maximums is a good place to start. Most cavities are somewhat rectangular in shape and the equation provided above can determine the possible resonant frequencies. Often, just the dominant mode must be damped. In this case the field is at a maximum at the midpoint of the cavity. If the problem is a second-order mode, there will be two field maximums at 1/3 and 2/3 of the way across the cavity, etc.

Determination of m , n , and p in the above equations plus knowledge of the frequency causing the problem will help determine the optimum absorber placement.

Elastomer absorbers can be easily cut with a die or a razor blade. Most are available with a peel-and-stick, pressure sensitive adhesive (PSA). This has become the application method of choice as it eliminates the need for solvent-based material and messy adhesives. The adhesion qualities of today's pressure-sensitive adhesive (PSA) materials are outstanding. Cost is always the most important variable. Most budgets did not originally allow for absorber material. Absorber is still considered to be something of a band-aid applied only because the engineer "failed." Absorbers tend to be a cost-effective solution as opposed to re-engineering a circuit board cover or relocating circuit elements to eliminate a problem.

Conclusions

Cavity resonance can cause serious problems in circuit operation. Resonances will occur at frequencies beginning when the cavity is roughly one wavelength in dimension. Inter-component coupling and shielding failure are common manifestations of cavity resonances. Cavity resonances can be reduced or eliminated with the use of absorber material. Different absorber materials are more effective at different frequencies. Magnetic absorbers are most effective at damping cavity resonances though dielectric absorbers are effective in the upper mmWave band.
